

SenseLine™ ELDS™ 2000 Series Simultaneous Methane & Hydrogen Sulfide

Fulfilling the promise of open path gas detection (OPGD)

About SenseLine ELDS OPGD

SenseLine is a new open path gas detection (OPGD) system from Senscient Inc, based on innovative Enhanced Laser Diode Spectroscopy™ (ELDS) detection technology. SenseLine OPGD systems provide many unique and attractive features designed to fulfill the promise of truly fit-and-forget open path gas detection.

Detects both toxic & flammable gases for up to 80% reduction in comprehensive gas detection project costs with true Fit-&-Forget functionality.

FIRST and ONLY Toxic open path system to meet current industry Safety Performance Standards.

FIRST and ONLY gas detector with Simu-Gas, an electronic, remote functionality check.

3 orders of magnitude greater sensitivity for combustible gases versus conventional OP systems. Perfect for detection of hazardous gases in critical applications.

Backed by a network of industry-leading gas detection solutions providers.

Proven technology, tested to meet oil and gas industry safety standards.



SenseLine 2000 Series Features / Benefits:

- Reliable, open path detection of both methane and hydrogen sulfide in a single unit.
- Faster response than any other hydrogen sulfide detection technology.
- No need to replace or re-calibrate sensors.
- No false alarms from any other gases including diesel fumes or oil mist.
- True ease-of-installation, with vibration and misalignment tolerant optics.
- SimuGas™ feature provides ability to accomplish on-demand, remote functionality testing right from the control room or PLC!

Applications:

Offshore Platforms, FPSO's, Onshore Petrochemical facilities and Refineries.

Theory of Operation:

Using a separate transmitter and receiver configuration, SenseLine 2000 Series OPGD systems can detect and measure methane and hydrogen sulfide over distances between 5 and 40 m. The ELDS technique measures the Harmonic Fingerprint™ introduced onto the transmitter's laser beam(s) by absorption by any target gas in the monitored path.

In the vast majority of instances, hydrogen sulfide is found as a component of the solution gas or natural gas present at the facility, intimately mixed with predominantly methane. When solution gas or natural gas containing hydrogen sulfide leaks, its components do not separate regardless of the density of the individual gases. It remains intimately mixed and the hydrogen sulfide follows the same leak path as the rest of the gas.



Senscient, Inc. • Phone: 281-639-9168 • Email: info@senscient.com • www.Senscient.com

120 Bayou Bend Drive • League City, Texas, USA 77573

SenseLine™ ELDS™ 2000 Series

Simultaneous Methane & Hydrogen Sulfide

Fulfilling the promise of open path gas detection (OPGD)

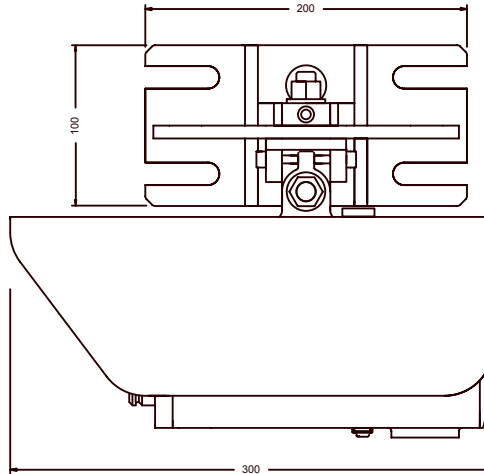
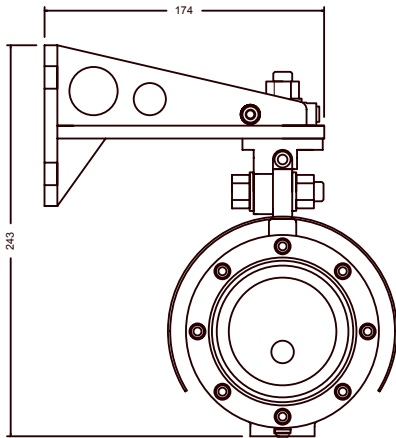

Specifications:

Gas	Methane and Hydrogen Sulfide
Methane Ranges	0-1000 ppm.m, 0-1LEL.m, 0-4LEL.m, 0-5 LEL.m
Hydrogen Sulfide	0-100 ppm.m, 0-250 ppm.m, 0-1000 ppm.m
Path-Length	5 – 40 m

Performance:

Response Time	T90 <= 3 seconds (Methane) T90 <= 5 seconds (Hydrogen Sulfide)
Resolution	0.5% FSD
Repeatability	<= +/- 2% FSD
Linearity	<= +/- 2% FSD
Zero Drift	<= +/- 1% FSD
Span Drift	<= +/- 2% FSD
Min. Alarm Threshold	Methane only - 200 ppm.m (or 10% FSD, whichever is greater) Sour gas - Hydrogen Sulfide @ 5 ppm.m over 5metres (25 ppm.m) confirmed by Methane at or above 25 ppm.m x MF. MF: Multiplication Factor - Min. ratio of concentration of Methane to Hydrogen Sulfide in the sour gas encountered at the facility.

Environmental:

Ingress Protection	IP66/67
Enclosure Material	316 stainless steel
Operating Temperature	-40° C to +65° C
Humidity	0 – 100% RH (non-condensing)
Vibration	0 – 100 Hz, 20 g
EMC	EN50270
Meteorological Visibility	Operates @ Met. Visibility >= Path-Length

Certification / Approvals:

FM	Class 1, Div 1, Groups B, C & D, -40 C to +65° C
CSA	Class 1, Div 1, Groups B, C & D, -40 C to +65° C
CENELEC (Hazardous Area)	EEx d, IIC, T4, -40° C to +65° C

Electrical:

Operating Voltage	+24 V nominal, operates correctly for supply voltages between +12 V and +32 V
Power Consumption	TX = 10 W (max), RX = 7.5 W (max)
Output (Analog 2 O/Ps)	4-20 mA (2 wire, isolated) Configurable for single wire, sink or source Capable of driving 0-600 Ohm load 3 mA (configurable 1 mA to 4 mA) 2.5 mA (configurable 0 mA to 3.5 mA)
Low Signal	3 mA (configurable 1 mA to 4 mA)
Beam Block	2.5 mA (configurable 0 mA to 3.5 mA)
Inhibit	2 mA (configurable 1 mA to 4 mA)
Fault	0 mA
Output (Digital 1 O/P)	RS485 (Isolated), MODBUS protocol

Mechanical:

Size	TX/RX	140 mm dia. x 300 mm
Weight	TX/RX	9 kg
Mounting	TX & RX units supplied fitted to a mounting bracket which incorporates holes / slots for fixing on flat surfaces or metal poles (4" to 6" diameter - requires U bolts).	

Optical:

The unit will operate correctly, without spurious readings or faults during conditions of misalignment or partial obscuration.

Alignment	+/- 0.5°
Obscuration	90%
Heated Optics	The window-lenses of the TX and RX units are heated.

Calibration, Testing & Maintenance:

Calibration	Units supplied factory calibrated for the specified target gas or gases. Units should not require re-calibration in service.
-------------	--

Part Numbers:

SenseLine V-GGGG-C

Where:-

V	= S =	Standard Range
GGGG	= 2001 =	0-1000 ppm.m Methane & 0-100 ppm.m Hydrogen Sulfide
	= 2002 =	0-1 LEL.m Methane & 0-100 ppm.m Hydrogen Sulfide
	= 2003 =	0-4 LEL.m Methane & 0-100 ppm.m Hydrogen Sulfide
	= 2004 =	0-5 LEL.m Methane & 0-100 ppm.m Hydrogen Sulfide
	= 2011 =	0-1000 ppm.m Methane & 0-250 ppm.m Hydrogen Sulfide
	= 2012 =	0-1 LEL.m Methane & 0-250 ppm.m Hydrogen Sulfide
	= 2013 =	0-4 LEL.m Methane & 0-250 ppm.m Hydrogen Sulfide
	= 2014 =	0-5 LEL.m Methane & 0-250 ppm.m Hydrogen Sulfide
	= 2021 =	0-1000 ppm.m Methane & 0-1000 ppm.m Hydrogen Sulfide
	= 2022 =	0-1 LEL.m Methane & 0-1000 ppm.m Hydrogen Sulfide
	= 2023 =	0-4 LEL.m Methane & 0-1000 ppm.m Hydrogen Sulfide
	= 2024 =	0-5 LEL.m Methane & 0-1000 ppm.m Hydrogen Sulfide

C	= 1 =	FM
	= 2 =	ATEX
	= 3 =	CSA

E.g. SenseLine M-2001-1 is a short range SenseLine OPGD calibrated for 0-1000 ppm.m and 0-100 ppm.m Hydrogen Sulfide with FM Approval.



Senscient, Inc. • Phone: 281-639-9168 • Email: info@senscient.com • www.Senscient.com

120 Bayou Bend Drive • League City, Texas, USA 77573